

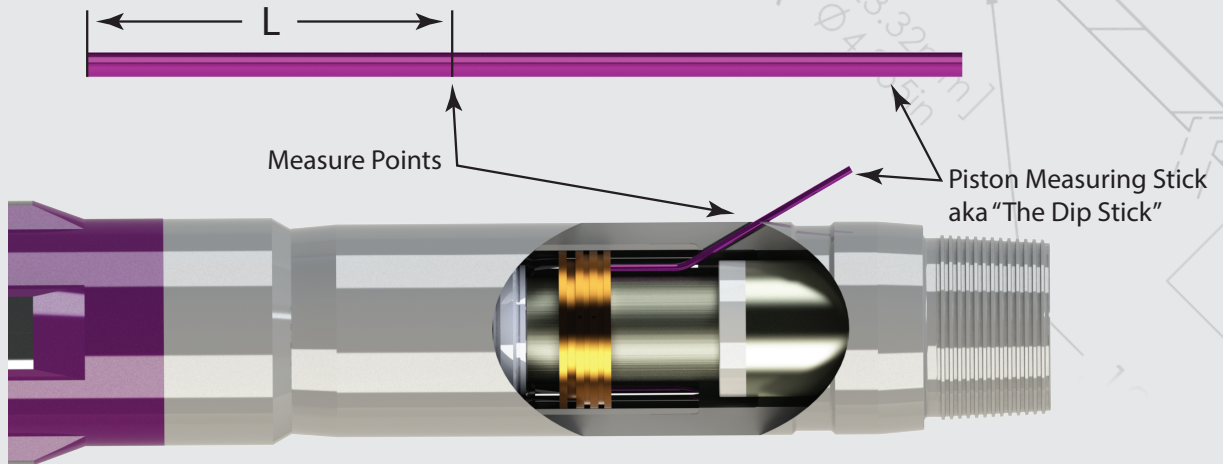

CAVARE

"Designing and Manufacturing Drilling Tools Since 1999"

# Oil Level Check for Easy Drill "S" Series Drilling Motor



Motor	Location of angled port from the end of bit box	Distance "L" where piston is installed at service	Distance "L" where piston is bottomed out	Distance "L" where motor should be returned for service
3 3/4 95mm	28" .71m	2.10" 53mm	4.10" 104mm	4.10" 104mm
4 3/4 121mm	40" 1.02m	3.00" 76mm	6.14" 155mm	5.00" 127mm
6 1/2 165mm	46" 1.17m	3.00" 76mm	5.90" 150mm	5.00" 127mm
8 203mm	55" 1.40m	3.75" 95mm	7.63" 193mm	5.75" 146mm
9 5/8 244mm	59" 1.50m	4.50" 114mm	8.50" 215mm	6.50" 165mm

Cavare

www.cavareinc.com  
sales@cavareinc.com